

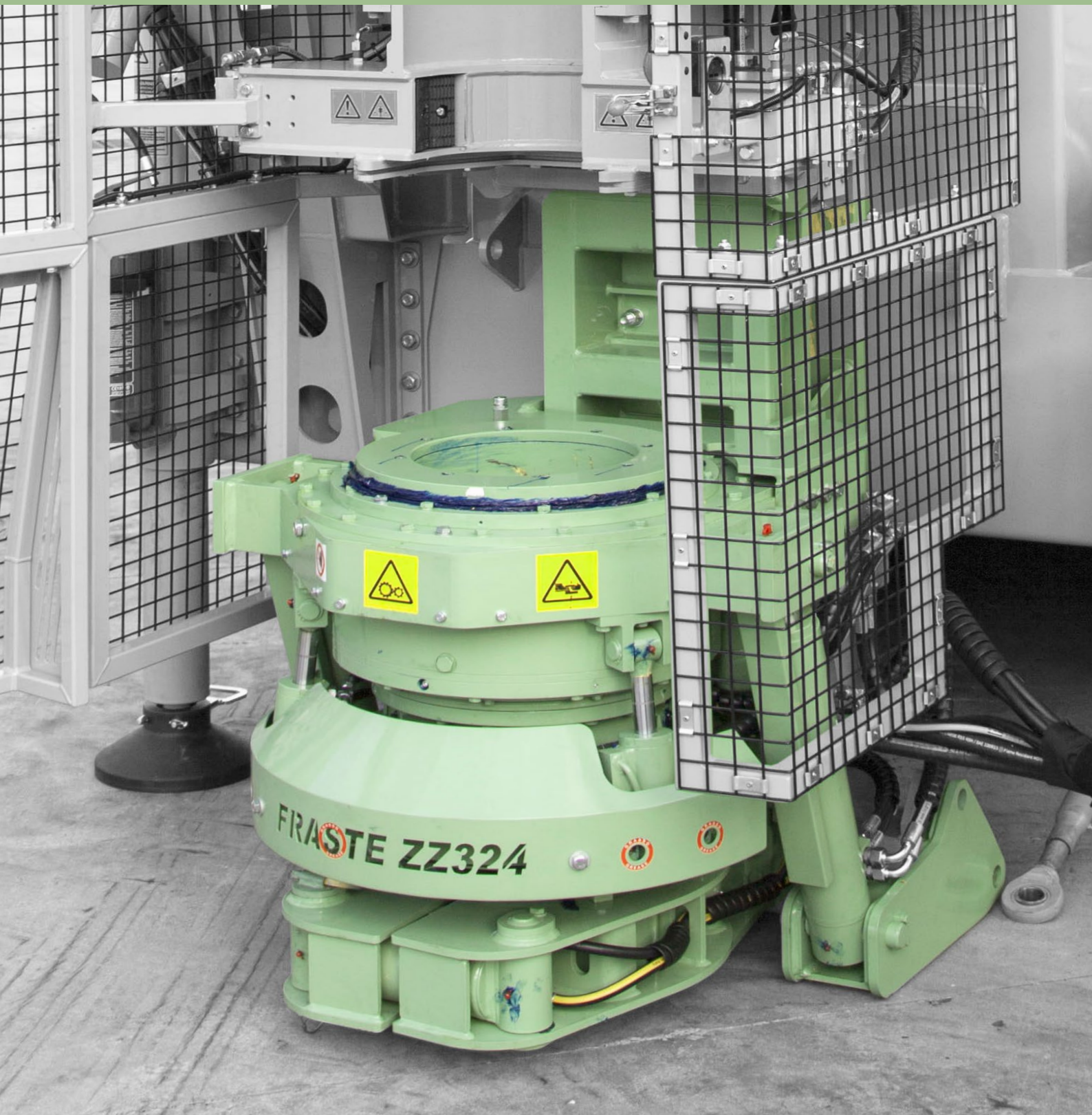

DRILLING RIGS
SINCE 1964



CASING PIPES ROTARY TABLE

ZZ





- 

Tavola per tubi di rivestimento ZZ FRASTE da applicare su perforatrici, adatta per tubi di rivestimento di vario diametro. Un elemento complementare che si aggiunge alla gamma di accessori FRASTE costruiti a corredo delle macchine per poter effettuare differenti tipi di perforazione. La tavola per tubi di rivestimento **ZZ FRASTE** è di solida costruzione e può essere applicata sia su macchine nuove che su macchine esistenti, purché di adeguate dimensioni. La particolarità di questa tavola per casing è il sistema di rotazione con l'azionamento della corona dentata per mezzo di due motori idraulici con ingranaggi, che riducono sensibilmente l'usura della ralla e la relativa manutenzione di routine.
- 



FRASTE ZZ Casing pipes rotary table to be applied on drilling rigs and suitable for different casing pipes diameters. This complementary device improves the FRASTE drilling accessories range that can be fitted on rigs for various drilling methods and jobs. The **FRASTE ZZ** casing pipe rotary table is a strong construction and it can be mounted either on new or used rigs, provided they have adequate sizes. Its main feature is that the crown wheel rotation is driven by two hydraulic motors with gears, that significantly reduce slewing ring wear and make routine maintenance easier.
- 

Table FRASTE ZZ pour tubages de revêtement à appliquer aux foreuses, adaptée aux tubages de différent diamètre. Un élément complémentaire qui s'ajoute à la gamme d'accessoires FRASTE construits pour équiper les machines pour différents types de forage. La structure de la table **FRASTE ZZ** pour tubages est solide et s'adapte aussi bien sur les nouvelles machines que sur les machines existantes, à condition qu'elles soient de dimensions appropriées. La particularité de cette table est le type de rotation avec l'entraînement de la couronne dentée par deux moteurs hydrauliques à engrenages, qui réduisent sensiblement l'usure de la couronne d'orientation et son entretien ordinaire.



 **FRASTE ZZ Verrohrungsdrehtisch für Futterrohre** unterschiedlichen Durchmessers geeignet. Ein Zusatzelement, dass das FRASTE Zubehörsortiment der Maschinen zur Durchführung unterschiedlicher Bohrarten bereichert. Der **FRASTE ZZ Verrohrungsdrehtisch** ist solide gebaut und kann sowohl an neuen als auch an bereits in Gebrauch befindlichen Maschinen angebracht werden, sofern sie die passenden Maße aufweisen. Die Besonderheit dieses Verrohrungsdrehtisch ist das Rotationssystem mit Kronenradantrieb mittels zweier Hydraulikmotoren mit Gänge, die den Verschleiß der Sattelkupplung und die damit verbundene routinemäßige Wartung erheblich reduzieren.

 **Mordaza giratoria para tubos de revestimiento FRASTE ZZ** a montar sobre las perforadoras, adecuada para tubos de revestimiento con distinto diámetro. Se añade así un elemento adicional a la gama **FRASTE** de accesorios realizadas para ser equipada a las perforadoras para realizar distintos tipos de perforación. La mordaza giratoria para tubos de revestimiento **FRASTE ZZ** está sólidamente construida y puede aplicarse a las máquinas nuevas como a aquéllas existentes, con tal que tengan unas dimensiones adecuadas. La característica particular de esta tabla está sin duda alguna el tipo de sistema de rotación, con accionamiento de la corona dentada por medio de dos motores hidráulicos de engranajes, que reducen en considerablemente el desgaste de la corona giratoria y simplifica su mantenimiento rutinario.



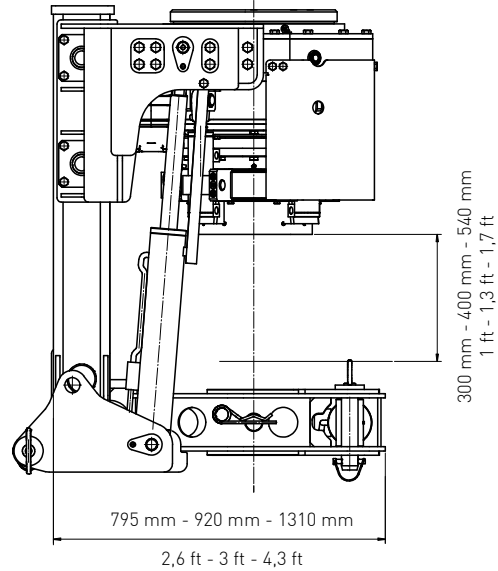
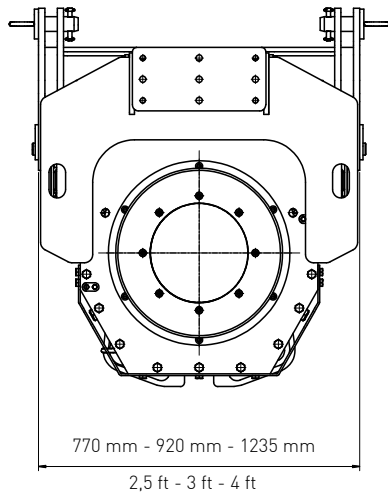
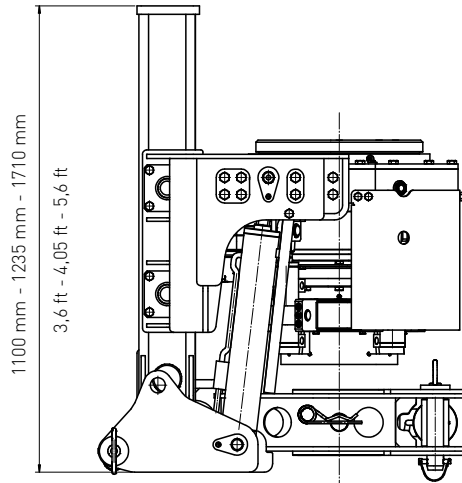
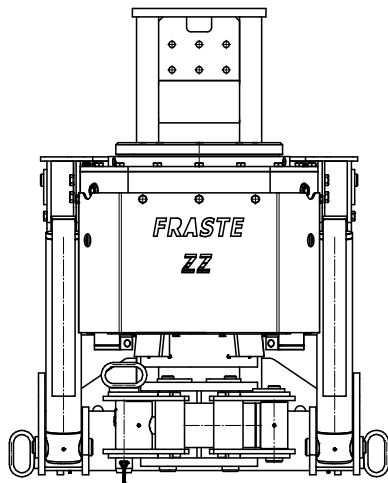

MODELLO	MODEL	MODÉLE	MODELL	MODELO	ZZ 219	ZZ 324	ZZ 419
Coppia	Torque	Couple	Drehmoment	Fuerza de rotacion	1300 daNm (9587 ft lbf)	2000 daNm (14750 ft lbf)	4000 daNm (28800 ft lbf)
Velocità	Speed	Vitesse	Geschwindigkeit	Velocidad	Max 18 rpm	Max 12 rpm	Max 9 rpm
Forza di chiusura	Clamping force	Force de serrage	Klemmkraft	Fuerza de cierre	14000 daN (30864 lbf)	12500 daN (28100 lbf)	24000 daN (53000 lbf)
Tiro	Pull-up	Tir	Zugkraft	Tiro	14000 daN (30864 lbf)	18000 daN (40460 lbf)	24000 daN (53000 lbf)
Spinta	Pull-down	Poussée	Andruck	Empuje	10500 daN (23148 lbf)	12000 daN (26900 lbf)	20000 daN (44100 lbf)
Corsa	Stroke	Course	Vorschub	Carrera	300 mm (1 ft)	400 mm (1,3 ft)	540 mm (1,7 ft)
Kit ganasce	Jaws kit	Kit machoires	Backen-Kit	kit de placas	Ø 152 mm (6")	Ø 178 mm (7")	Ø 219 mm (8 ^{5/8})
					Ø 168 mm (6 ^{5/8})	Ø 219 mm (8 ^{5/8})	Ø 273 mm (10 ^{3/4})
					Ø 178 mm (7")	Ø 273 mm (10 ^{3/4})	Ø 324 mm (12 ^{3/4})
					Ø 219 mm (8 ^{5/8})	Ø 324 mm (12 ^{3/4})	Ø 419 mm (16 ^{3/4})
PESO	WEIGHT	POIDS	GEWICHT	PESO	850 KG	1300 KG	1750 KG

I dati esposti sul presente catalogo possono variare senza preavviso - Specifications may change without notice - Ces caractéristiques peuvent être modifiées sans préavis
Technische Änderungen vorbehalten - Variaciones son premissibles sin previo aviso.