

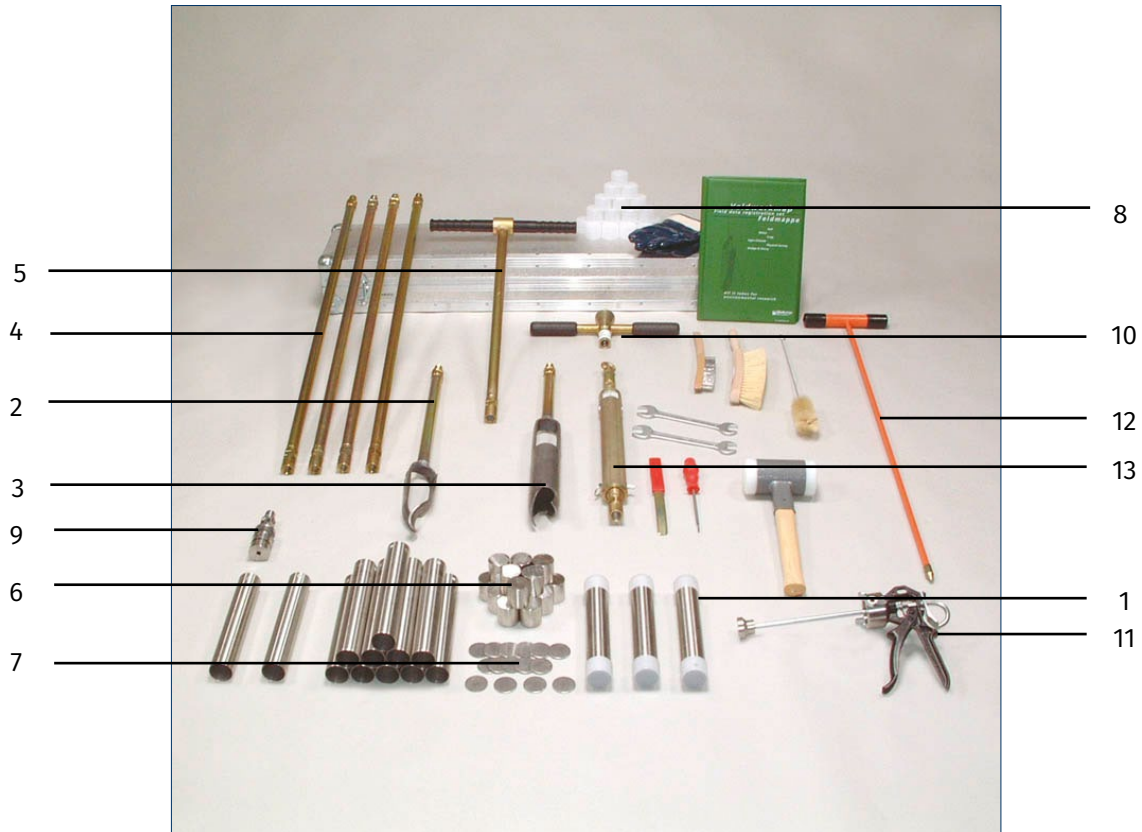

Soil coring kit for chemical soil research

Operating instructions



Meet the difference

Contents

On these operating instructions	3
Introduction	3
1. Description	3
1.1 Sample tube	3
1.2 Sample extruder	4
1.3 Augers	4
1.3.1 Edelman auger	4
1.3.2 Riverside auger	5
1.4 Down-the-hole hammer	5
2. Technical specifications.....	5
3. Safety	6
4. Preparing for use	6
5. Use of the equipment.....	6
5.1 Sampling.....	6
5.2 Down-the-hole hammer	9
5.3 Removing the sample from the tube.....	9
6. Application.....	10
7. Troubleshooting.....	10
8. Maintenance.....	10
Appendix: Rust on augers and gouges.....	11

Nothing in this publication may be reproduced and/or made public by means of print, photocopy, microfilm or any other means without previous written permission from Royal Eijkelkamp. Technical data can be amended without prior notification.
Royal Eijkelkamp is not responsible for (personal damage due to (improper) use of the product.
Royal Eijkelkamp is interested in your reactions and remarks about its products and operating instructions.

On these operating instructions



When the symbol shown on the left is placed before a piece of text, this means that an important instruction follows.



When the symbol shown on the left is placed before a piece of text, this means that an important warning follows pointing out a risk of injury to the user or damage to the device. The user is always responsible for it own personal protection.

Text

Text in italics means that the actual text is shown on the display screen.

Introduction

This soil coring kit allows sampling for environmental research of soil containing volatile components. During sampling the sample is pushed into the sample tube (1) upon which the tube is shut off. This will optimally prevent volatilisation and oxidation of the soil sample. The method employed meets the NEN 5743 standard. Sampling should take place according to NEN 5740 and NEN 5743.

1. Description

This soil coring kit, used to establish the presence of volatile components, is suitable for augering down to a depth of 5 m. The set contains an Edelman auger (2), the Riverside auger (3), extension rods (4) (not on the photo: 1x extension rod 50 cm and 1x push-pull handle), handle with grip (5), sample tubes (1), filling blocks (6), caps (8), insulation plates (7), coring apparatus (9), handle with beating head (10), sample extruder for sample tube (11), utility probe (12), down-the-hole hammer (13) maintenance items and various accessories in a transport case (see photo overleaf). The set weighs 33,5 kg.

1.1 Sample tube

Sampling takes place using a coring apparatus to which a thin-walled, stainless steel sample tube (1) is attached. Preferably the sample tube is pushed into the soil, if necessary an impact-absorbing hammer can be used. The sample tube coring apparatus is fitted with a valve (12) allowing de-pressurisation during sampling, and the underpressure to hold the sample material in the tube during withdrawal. An O-ring (13) secures the airtight connection between the coring apparatus and the sample tube. A filling block (6), insulation plates (7) and 2 caps (8) close off the sample tube after sampling.

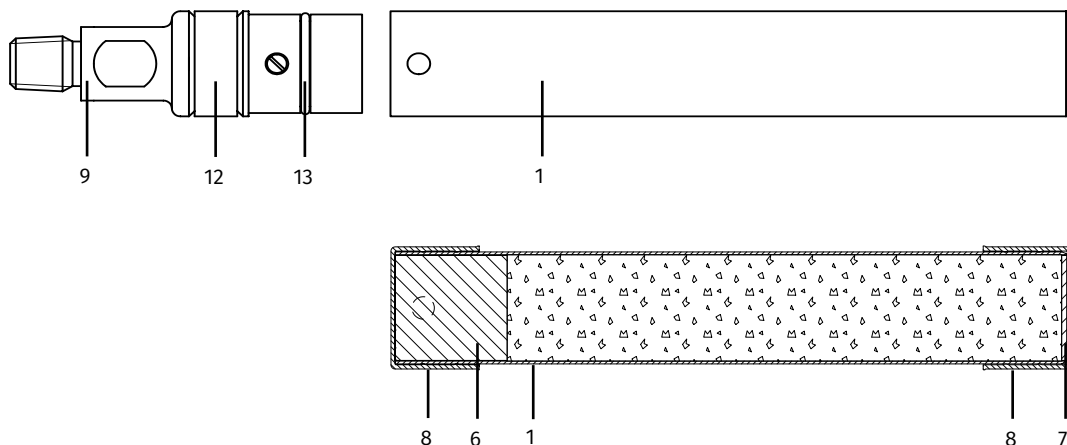

1.2 Sample extruder

The sample extruder consists of a frame (4), grip (6), a blocking strip (7) and two springs (7). A sample tube holder (4) is connected to the frame to hold the sample tube (1) by using two wing bolts (3). An extruder block (2) is attached to the rod (5).

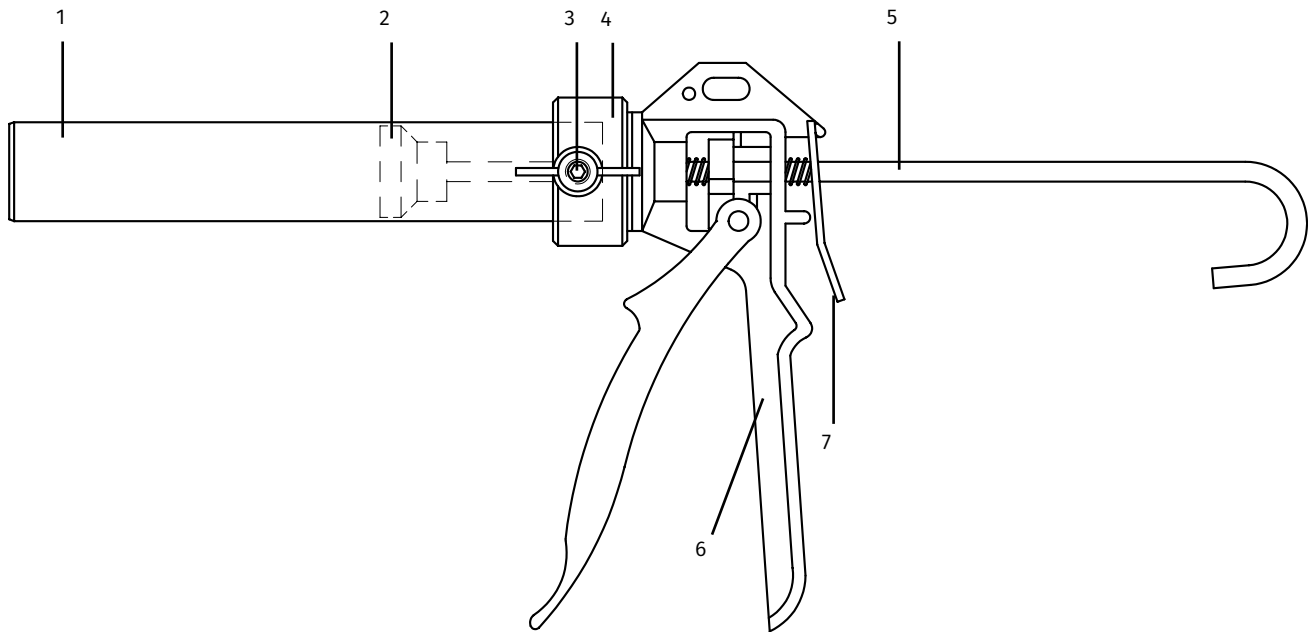

1.3 Augers

Both the Edelman and the Riverside auger can be attached to an extension rod or to the handle with synthetic grip.

1.3.1 Edelman auger

The Edelman auger body is conical in shape and consists of 2 blades (22) joined in a bit (23). The top of the blades is welded to a bracket (24), which is connected to the auger rod (25) (see figure at right). The blades are vaulted and when entering the soil the sample is dug up and evenly guided into the inside of the auger body. The vaulting of the blades not only promotes digging up but also ensures a firm grip of the sample while permitting easy emptying of the auger body. The combination-type permits a good hold of moderately cohesive soils, while cohesive soils can easily be removed.

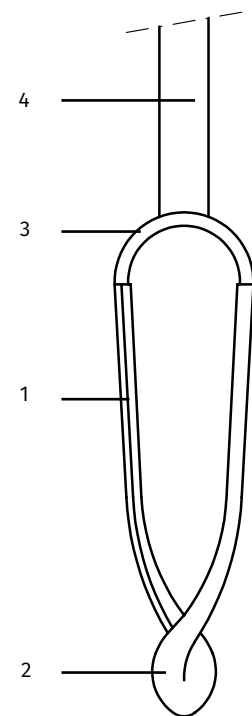

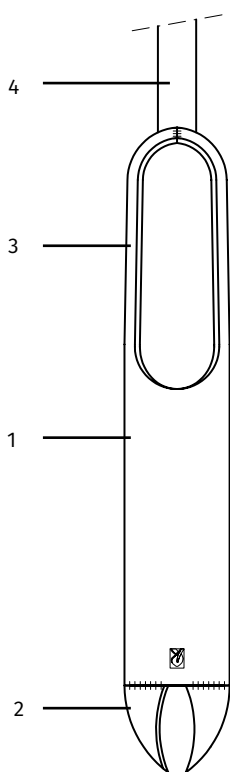

1.3.2 Riverside auger

The Riverside auger is suitable for dry and coarse soils, in addition it is applied to obtain a borehole with a level surface (see figure, page 6). The auger body has an open tube (26) with two beak-like bits (27) at its base. A bow bracket (28) connects the open tube to the auger rod. The extremities of the bits are skewed and scrape the soil, pressing the sample evenly into the tube. The diameter of the auger bits slightly exceeds the tube's diameter so as to reduce friction between soil and tube to a minimum. Turning over and tapping the auger on the ground will remove the sample.

1.4 Down-the-hole hammer

The sample tube attached to the coring apparatus is driven into the ground using a down-the-hole hammer. During pounding the upper/outer part (A), a heavy-duty tube with beating head, plummets, thereby causing the impact of the lower/inner part (B) to drive the sample tube into the soil. An M12 socket cap (C) sliding through the lower/inner part into a slot in the upper/outer part prevents any twisting movement and limits the impact to 29 cm.

A cotter pin (D) locks the hammer. If necessary a wire eye (E) can be attached to the hammer.

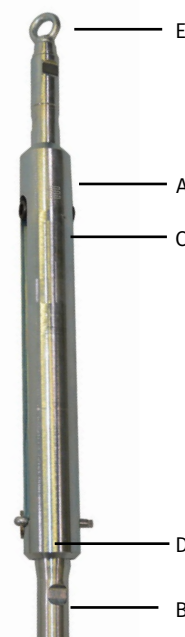

2. Technical specifications

- Suitable for sampling down to a depth of 5 m
- Sampling without volatilisation of sampling components
- No physical contact between the sample and synthetic materials

Part

Sample tube

Coring apparatus

Filling block

Insulation plate

Cap

Edelman auger

Riverside auger

Down-the-hole hammerstroke length 29 cm, length 50 cm, ϕ 51 mm, weight 3.5 kg

Probing cone

Transport case

Characteristics

Cleaned with detergent and water. Stainless steel, ϕ 38 mm, length 240 mm, contents 226 ml.

Stainless steel, ϕ 38 mm, length 40 mm, O-ring 32,2 x 3 mm

Cleaned with detergent and water. Stainless steel, ϕ 38 mm, thickness 40 mm

Cleaned with detergent and water. Stainless steel, ϕ 38 mm, thickness 2 mm

natural PE, ϕ 40 mm

iron-manganese steel (not stainless steel, non-toxic)

iron-manganese steel (not stainless steel, non-toxic)

glass fibre, cone ϕ 19 mm, rod ϕ 12.5 mm, length 105 mm

aluminium/wood, outside dimensions 108 x 23 x 14 cm

3. Safety



Prior to augering use the utility probe to check for cables, tubes and pipes (inquire at the 'KLIC' – Kabels en Leidingen Informatie Centrum/ Cables and Wires Information Centre). If necessary, select another spot to auger.



Beware of synthetic slivers from power cables. In principle the current will flow from the auger into the ground when a cable is hit. While augering hold the auger by its synthetic handle. It is fully insulated should you hit an electricity cable.



Augers with a total length of over 4 meter should be handled in parts. This will prevent damage to the rods and reduce the risk of being hit by augers tipping over. This applies to inserting and hoisting the auger.



Do not force, or pound on, the auger. This may cause serious damage, such as cracks or snapped joints.



Wear sturdy gloves. This will prevent you from cutting your fingers.



Fill up the borehole with (permeable) soil, bentonite or special bentonite plugs after augering. This will prevent humans or animals to trip into the hole and incur injuries. In addition it will help to recover impermeable soil layers.



Make sure your fingers do not get caught in the extruder.



Be cautious during a thunderstorm. Lightning strokes often occur in the open field, in particular when one holds metal objects.



Always use the impact-absorbing steel hammer if force is necessary. This is safer and will prevent damage to the auger. Avoid using standard metal hammers. This may cause damage to the auger and a bouncing hammer may lead to injuries.

4. Preparing for use

1. Attach an extension rod (4) to the upper part with beating head (10) and to the coring apparatus (9).
2. Use a screwdriver to turn the M4 screws into the coring apparatus.
3. Slide a clean sample tube over the coring apparatus and position the screw holes.
4. Use the screwdriver to loosen both screws 360° so as to attach the sample tube to the coring apparatus.
The sample tube is ready for use.

5. Use of the equipment

5.1 Sampling

1. Plan the location and depth of the boreholes.



Prior to augering use the utility probe to check for cables, tubes and pipes (inquire at the 'KLIC' – Kabels en Leidingen Informatie Centrum/ Cables and Wires Information Centre). If necessary, select another spot to auger.



Beware of synthetic slivers from power cables. In principle the current will flow from the auger into the ground when a cable is hit. While augering hold the auger by its synthetic handle. It is fully insulated should you hit an electricity cable.

2. Attach the synthetic grip to the handle (5).
3. Attach the Edelman auger (2) to the handle (5).



In the case the augers supplied are not satisfactory, use another type like a percussion gouge.

4. Hold the auger by its handle and place it in the borehole. Rotate it clockwise while gently pushing it into the soil. Upon 2¼ rotations (360°) the auger should have dug 10 cm. The auger body will be filled up to its bracket with slightly disturbed soil material. Depending on the type of soil additional rotations may be necessary. Withdraw the auger after sampling; hoist it while gently rotating the auger. To release the cohesive material hold the auger askew on the surface, rotate it 180° while pressing it into the ground. The sample should detach itself and can be taken out by hand or by lightly tapping the auger. Moderately cohesive material will detach itself immediately. Auger again until the desired depth has been reached.

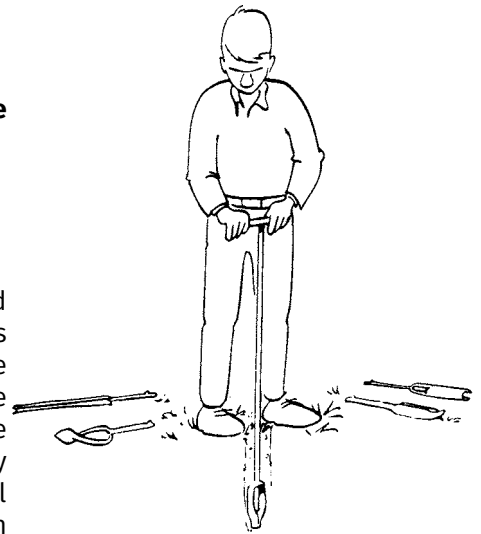

Caution:

- Do not overfill the auger body. Superfluous material will coat the auger hole, which hinders pulling out subsequent soil layers. When augering under the water table an overfilled auger acts like a plunger, which hampers hoisting the auger and results in loss of sample material.
- Loss of sample material. Hoist the auger with sample while lightly rotating it, do not pull it straight out.

5. Detach the handle (5) from the Edelman auger (2) and attach its to the Riverside auger (3).
6. Screw and press the auger into the soil. The Riverside auger creates a level horizontal profile. Pull out the auger without rotating it. Tap it gently on the surface and the sample will detach itself.
7. Push the sample tube vertically into the soil. Air will escape through the valve (12) in the coring apparatus. If necessary, use the impact-absorbing hammer or drop hammer to drive the sample tube into the ground.



Preferably samples are taken from undisturbed soil so as to avoid mixing with air. Also during transport and storage the samples should remain undisturbed. In the case the sample tube is not fully filled, fill it up with filling blocks and insulation plates.



Sampling for research into the presence of volatile components purposes will only yield satisfactory results if sampling takes place at sufficient depth. Only at a depth of over ± 1 m wind, or day and night temperatures ventilating the soil will not affect sampling.



When sampling under water the coring tube will be filled with air until soil enters the tube. Subsequently the soil forces the air out through the rubber valve. Consequently, sampling is not 100% anaerobic. However, perfectly anaerobic sampling is possible using the piston sampler and the bio-core sample splitting tube (04.26)

8. When the sample tube is filled rotate it 90° so as to break the sample free from the soil. Hoist the sample tube. The underpressure above the sample will hold the sample material in the tube.



To withdraw the auger keep your back straight and your knees bent to prevent injuries.

9. Place an insulation plate on the bottom end of the sample tube (1), place a cap (8) over it.
10. Screw the two M4 bolts in the coring apparatus and remove the sample tube.
11. Place a filling block in the sample tube on the same point of attachment as the coring apparatus during sampling. Place a cap on the sample tube.
12. Number the sample tube and store it cooled.

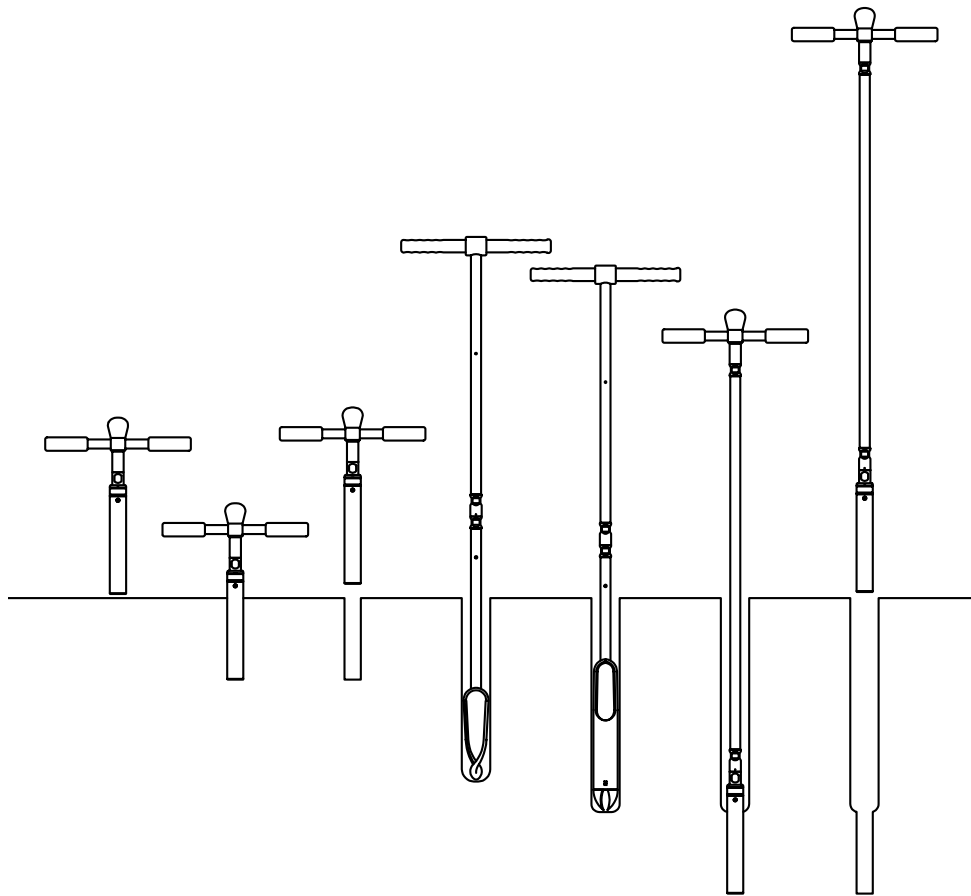

 **Make sure the sample does not freeze up.**

 **Heavily polluted sample tubes may be tightly wrapped in aluminium foil.**

13. Slide a clean sample tube over the coring apparatus and position the screw holes facing the M4 screws.
14. Use the screwdriver to loosen both screws 360° so as to attach the sample tube to the coring apparatus.

One or several extension rods are attached when augering over 1.20 m of depth.

1. Place the Edelman- Riverside- or sample auger besides the borehole.
2. Use a spanner to detach the upper part from the bottom part.
3. Use a spanner to attach an extension rod between the upper and bottom part.

Augers over 4 meter should be handled in parts. This will prevent damage to the rods and reduce the risk of being hit by augers tipping over. This applies to inserting and hoisting the auger.

1. Insert the auger in the borehole and place the bottom part on end for approximately 50 cm.
Grip the auger firmly!
2. To connect: use a spanner to tighten the two parts. To split: use a spanner to unscrew the two parts.

5.2 Down-the-hole hammer



Wear work gloves

There are three methods of using the down-the-hole-type hammer:

1. On top of the extension rods. The steel hammer is fitted with an upper part (after removing the locking pin (D)) so as to allow free vertical movement. Re-attach the pin before hoisting the hammer and rods.
2. Between the extension rods and the coring apparatus (9). This is the recommended method. It relieves the rods and yields more effective force of impact. However, the hammer should be able to pass through the borehole.
3. Between a cable or cord and the apparatus to drive in. To that purpose attach a wire eye to the steel hammer. Persistent hammering will drive the sample tube solidly into the soil. Withdraw with care. Use a strong steel cable or a 6-mm non-stretch cord made of kevlar, twaron, dyneema or aramide to make sure the coring apparatus does not unexpectedly slip out of the borehole.

5.3 Removing the sample from the tube

1. Unscrew the wing bolts (19) until they no longer protrude inward.
2. Simultaneously press the blocking strip (16) and slide in the rod (20).
3. Remove the filling block from the sample tube after removing the cap located at the side of the Eijkelkamp logo.
4. Place the sample tube in the container such that the wing bolts can be screwed into the holes of the sample tube.



To avoid damage to the sample tube only use wing screws exactly fitting the holes of the sample tube.

5. Fully screw in the wing bolts.
6. Subsequently remove the cap and insulation plate from the tube.
7. Remove the sample from the tube by repeatedly pressing and releasing the grip.
8. Remove the sample tube and clean with the tube cleaner. Rinse well with running water and let it dry. Soak first in detergent when very dirty.

6. Application

- Soil sampling for research into the presence of very volatile components such as benzene, toluene, xylene and chlorinated hydrocarbon according to NEN 5743.
- Soil sampling for determining the volume percentage of moist.

7. Troubleshooting

The Edelman combination auger and the Riverside auger do not successfully remove the soil

- Use another type of auger

Stones cause damage to the sample tube.

- Some small damage can be repaired using pliers. If necessary, the extruder (11) can be used to press a filling block (6) through the sample tube.
- Make sure to have sufficient spare sample tubes. Sample tubes are available in sets of five.

The sample cannot be held in the tube.

- The O-ring or valve is defect. Attaching a sample tube to the coring apparatus and blowing the sample tube while holding the valve part under water can verify this. Replace the O-ring and clean/adjust the valve.

Filling the sample tube is not successful

- The valve is defect. Remove any dirt
- The sample tube has not been driven sufficiently deep into the soil.
- Fill the half-full sample tube with clean filter sand.
- The sample is very inconsistent and cannot force the air through the valve. Use the piston sampler instead.

8. Maintenance

- Keep tools well clean, rinse with water to remove dirt.
- Clean the parts well after sampling. Use different brushes. The tube cleaner is used to clean the inside of the tubes. Rinse well with running water. Unscrew the parts for drying.



Do not use the steel brush to clean the coring apparatus. It may damage the valve and the O-ring.

- Replace the O-ring or valve in the case of damage.
- The auger bodies need no whetting, use keeps them sharp-edged. Under normal conditions oxidation is not detrimental to the auger and will vanish upon use.

Appendix: Rust on augers and gouges

These augers and gouges are made of high tensile-strength forgeable iron-manganese steel. Both iron and manganese are non-toxic metals, abundant in the earth's crust on which we live. Natural concentrations are very high. During storage and transport some rust may develop on the bare metal surface. During first use this rust will scour off quickly. You may also scour with some wet sand prior to first use. The auger or gouge is then ready for sampling of soil on all metals like zinc, cadmium, chromium, copper and even iron and manganese!

Question 1: How do I clean and maintain my augers / gouges?

In practice augers keep themselves clean (and sharp) by the high friction of soil particles rubbing the augers surface. Augers or gouges used in acid, saline or alkaline soil are prone to oxidation and should be rinsed with pH neutral water after use. After a drilling in an oil-polluted borehole you may clean the auger with a brush in a bucket with water with neutral baby-shampoo added. Spraying our detergent 20.05.29 is very effective too and will also mobilize trace-metals, even the zinc plating from the extension rods! Use this detergent with care or limit the use to stainless steel or plastic tools only. Isopropylalcohol on a tissue is fine for rapid on-site cleaning. Acetone is more effective and will even remove tars from metals. Dismantle coupling sleeves and other loose parts prior to cleaning to allow rapid and complete drying after the final water rinse. Store in a well ventilated area free from dust and, for plastic materials, smells.

Question 2: Why did we not prevent the development of natural rust?

A paint will blister off quickly and will pollute samples with a variety of organic pollutants during a prolonged period, necessitating a difficult and cumbersome cleaning procedure prior to first use.

A zinc plating is very soft. The zinc will be scratched off in a few dozens of drillings resulting in measurable quantities of zinc in your soil samples and influencing your measurements during a prolonged period. After a few days or weeks the zinc has completely disappeared and is not effective anymore.

A wax or grease is easy to put on, but fairly hard to remove and, again, risky. Greases, oils and waxes will influence a gas chromatogram (GC) made from soil samples taken with such an auger or gouge. In addition the layer is sticky and it is unavoidable that it will spread all over in carrying bag or case, extension rods, gloves and consequently soil samples. This should be avoided at all times.

Question 3: The extension rods and upper part are zinc plated. Does this zinc plating contaminate the soil sample?

No, since there is no intense scouring contact between soil sample and the rods there is no influence.

Question 4: Do stainless steel soil samplers (coring tubes and rings) contaminate soil samples?

Stainless steel is an alloy of high percentages of mainly chrome, iron and nickel. Alloys have characteristics that are different from the characteristics of a simple "mix" of these metals! Stainless steel is so chemically stable that no loose oxides are formed. It is also hard; scouring with soil will not lead to detectable levels of iron, chromium or nickel concentrations in soil.

Question 5: Does the chromium plated gouge Model P (04.03) contaminate a soil sample?

This gouge is plated with a pure thick layer of nice shining chromium. Chromium is an extremely hard metal and will only and partly be rubbed off in years of use! Although there is very little chance that these quantities will contaminate a sample with Chromium we would not recommend this gouge as first choice for soil analysis on chromium.