



**DRILLING RIGS
SINCE 1964**



FRASTE BREAKOUT BENCH **FBB**



FRASTE FBB Banco svita martelli

FRASTE offre un sistema di svitamento appositamente progettato per un rapido cambio di punte e per una facile manutenzione/riparazione di martelli, progettato per lavorare direttamente in cantiere.

Lo svitatore **FBB FRASTE** utilizza ganasce heavy-duty per svitare/avvitare rapidamente punte, giunti per martello fondo foro e altre connessioni API ed agevola e velocizza ogni operazione.

È progettato per funzionare in sicurezza in posizione orizzontale. Le apposite fessure per le forche del carrello elevatore ne facilitano il carico e lo scarico.

Con la sua potenza ed adattabilità, il sistema di svitamento FRASTE è l'ideale per lo svitamento/avvitamento di una vasta gamma di accessori di perforazione.

Azionamento completamente idraulico, collegamento con innesti rapidi.



FBB FRASTE Breakout Bench

FRASTE offers a special breakout system for quick bits change and easy hammer maintenance or repair, designed to work directly on job site.

FBB FRASTE breakout machine uses heavy-duty jaws to quickly breakout or make-up bits, DTH hammer joints and other API tool connections, to keep your operation smooth and quick. It is designed to safely operate in the horizontal position. Forklift slots make easy loading and unloading.

With its power and adjustability, the FRASTE breakout system is ideal for breakout / makeup in a wide range of drilling applications.

The Break out Bench is hydraulic operated with hydraulic quick connector.



 **Banc de Déblocage FRASTE FBB**
FRASTE offre un système de déblocage spécifiquement conçu pour un changement rapide des forets et un facile entretien/réparation des marteaux, conçu pour travailler directement sur le chantier.

Le **FBB FRASTE** utilise des mâchoires renforcées pour dévisser/ visser rapidement les forets, les joints pour le marteau à fond de trou les autres joints API en facilitant et accélérant chaque opération. Conçu pour fonctionner en sécurité en position horizontale. Les fentes afférentes pour les fourches du chariot élévateur en facilitent le chargement et le déchargement.

Grace à sa puissance et adaptabilité, le système de déblocage FRASTE est parfait pour le dévissage/vissage. Entraînement entièrement hydraulique, connexion avec embrayages rapides.

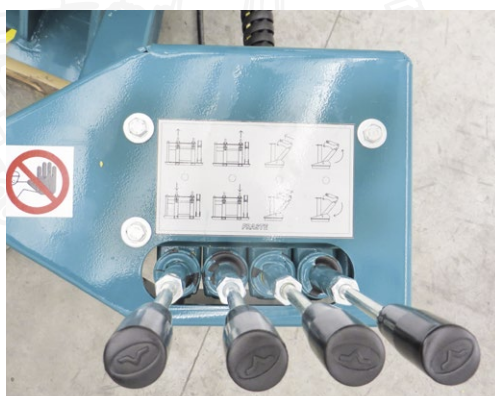

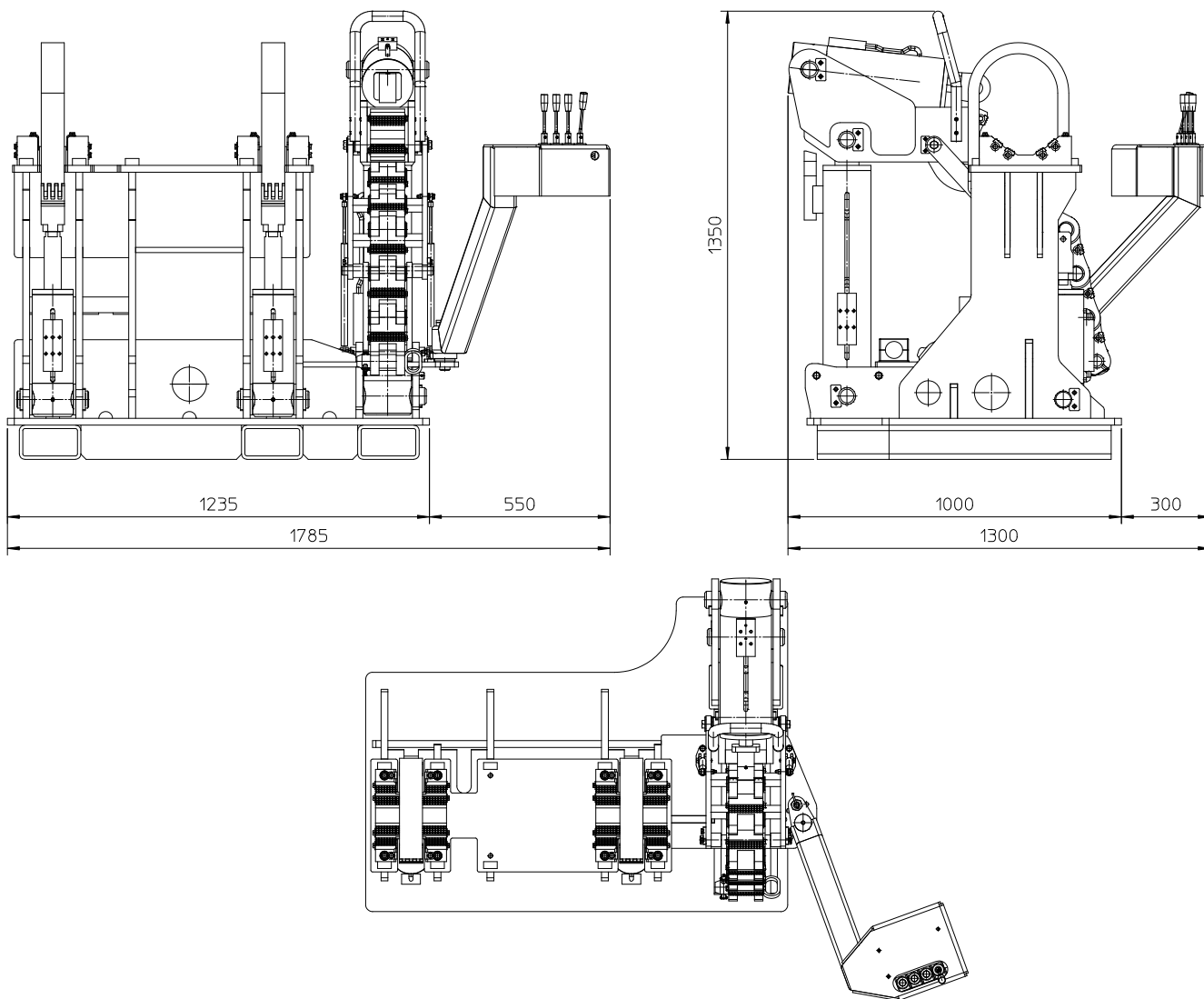

Potenza idraulica richiesta	Required hydr. power	Puissance hydraulique demandée	35 l/min. - 170 bar
Diametro martello	DTH hammer diameter range	Fond de trou DTH	6" - 12" (adattatore incluso) (adapter included) (Adaptateur inclus)
Coppia di svitamento max	Max break-out torque	Couple de dévissage maxi	10000 daNm
Coppia di avvitamento max	Max make-up torque	Couple de vissage maxi	10000 daNm
Peso	Weight	Poids	1200 kg

I dati esposti sul presente catalogo possono variare senza preavviso - Specifications may change without notice - Ces caractéristiques peuvent être modifiées sans préavis
Technische Änderungen vorbehalten - Variaciones son premissibles sin previo aviso.